

CUSTOMER TECHNICAL MEMO

Subject HE958 Hunter EVO Acoustic
Frame Sill

Date: October 2016

Author: Product Development Team

We are pleased to advise we have released a new sill section to suit our 150mm Hunter Evo Acoustic Framing (refer attached page).

As this section is open backed and not a hollow, it now facilitates masonry anchor clearances. Previously the hollow sill / transom HE954 needed to be relieved for these fixings.

HE954 now remains as a transom.

Code	Description
1600858	HE958 Hunter Evo Acoustic Frame Sill

This new section will initially be stocked in our Sydney Branch.

Kind Regards

Product Development Team



Extrusions

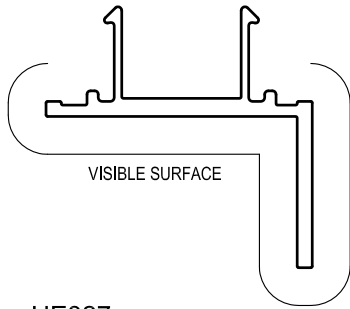

HE327
35mm AWNING
SASH ADAPTOR

Mass. 0.395 Kg/m
Anod. Per. 171
Paint Per. 100

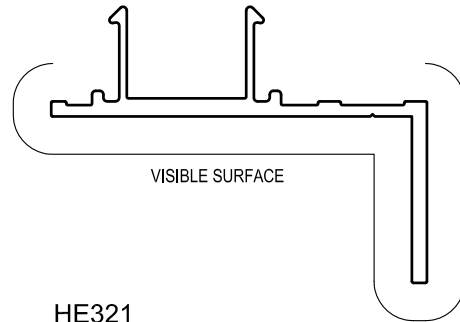

HE321
50mm AWNING
SASH ADAPTOR

Mass. 0.470 Kg/m
Anod. Per. 205
Paint Per. 100

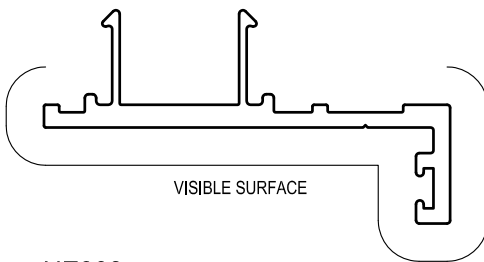

HE308
45mm DOOR STOP

Mass. 0.579 Kg/m
Anod. Per. 212
Paint Per. 100

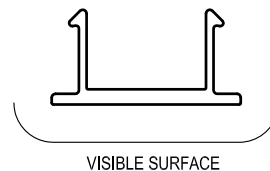

HE320
SINGLE GLAZE
POCKET FILLER

Mass. 0.188 Kg/m
Anod. Per. 100
Paint Per. 100

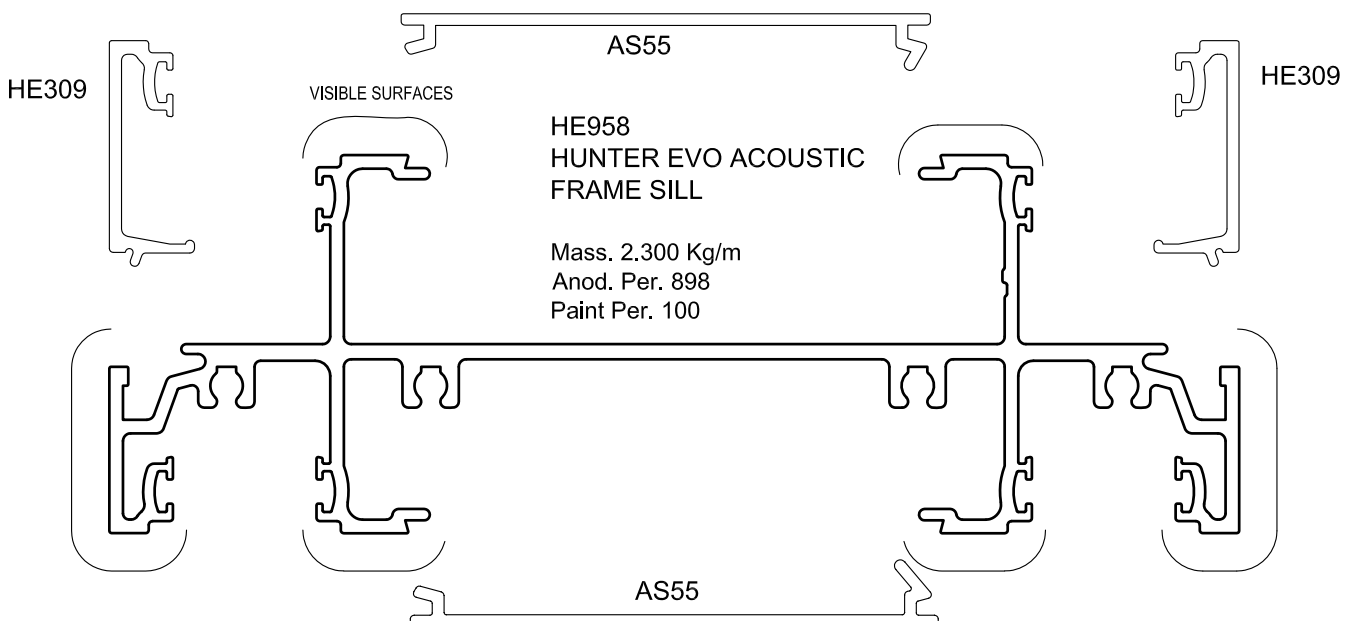

HE958
HUNTER EVO ACOUSTIC
FRAME SILL

Mass. 2.300 Kg/m
Anod. Per. 898
Paint Per. 100